



佛山市泓佳机械设备有限公司  
FOSHAN HONGJIA MACHINERY CO.,LTD.

📍 : 中国广东省佛山市南海区狮山镇塘头鸿盈工业区 1 号  
1# Hongying Industrial Zone, Tangtou, Shishan Town,  
Nanhai Dist., Foshan, Guangdong, P.R.China

☎ : +86-757-81081122 / 81081115

🌐 中文 / CN: [www.hongjia86.com](http://www.hongjia86.com)

✉ 中文 / CN: [hj@hongjia86.com](mailto:hj@hongjia86.com)

🌐 英文 / EN: [www.hongjia-machine.com](http://www.hongjia-machine.com)

✉ 英文 / EN: [hongjiamachine@gmail.com](mailto:hongjiamachine@gmail.com)

2020/03



SERIOUSLY ENGINEERED.

泓佳机械

METAL COIL SLITTING &  
CUT TO LENGTH LINE  
MANUFACTURER  
金属带材剪切生产线





## 关于我们

佛山市泓佳机械设备有限公司是一家集研发、设计、生产为一体的高新技术型企业，专业从事非标准及专用冶金精整设备设计研发与加工制造。公司成立至今，凭借专业的水平和成熟的技术，在引进消化吸收国外先进技术的基础上成功研发出金属卷带纵剪、横切、飞剪、纵剪横切联合机组等系列产品，获得了用户广泛的应用和一致的好评，其中一些产品在国内处于领先地位，部分产品可替代进口。精湛的技术、可靠的产品质量及完善的售后服务，使得企业在十余年的发展历程中取得了骄人的业绩，在业内深得广泛的认可与良好的口碑。

公司在发展的过程中，不断与国内外同行交流合作，创新研发、设计和调试服务能力迅速提高，规模不断扩大。一流的硬件环境加以团结、高效、专业的优秀团队使得公司充满了新鲜活力与发展动力。可为国内外各金属加工企业提供优质的精整设备及优良的技术服务。

“强化质量意识，持续改进体系，奉献精品设计，提供优质服务”的质量方针是泓佳不断的追求。

“道勤志远，创新求存”的经营理念是企业永恒的主题。泓佳机械将秉承企业家精神，把握历史契机，追求卓越，愿与国内外各界合作伙伴携手并进，共创辉煌明天！

## About us

FOSHAN HONGJIA MACHINERY CO., LTD. --- HONJIA, is a high-tech enterprise which integrates “research + design + manufacturing” professional nonstandard metallurgy finishing machinery. Basing on the latest science introduced and absorbed from abroad, the company had created a series of metallurgy machines depending on its professional and mature technology, which includes: **Slitting Line (SL), Cut to Length Line(CTL), Flying Cut to Length Line (FCTL), Slitting and Cut to Length Combined Line (SL.CTL)**, etc. HONJIA products, are very well accepted by end users and enjoying good comments. Some of our technology is taking the lead in China, and some products can take place with imported brands. With more than ten years' hardworking, HONJIA has achieved very good fame and sales record owing to its reliable product quality and perfect after sales service.

Through continuously cooperated with the foreign and domestic partners, the designing and manufacturing ability, after sales capacity of the company had got greatly improved. Depending on the first-class hardware environment and excellent team, the company emerged into a lively circumstance and full of energy. HONJIA is ready to provide quality machines and excellent technical services for metal processing enterprises at home and abroad.

"Quality oriented, continuous innovation, pursuit of fine design, excellent services", this is the policy of HONJIA.

"Hardworking---for great ambition; Innovation---for survival" will always be the spirit and main topic of the company. HONJIA MACHINERY is willing to cooperate with domestic and foreign partners, going hand in hand and create the brilliant tomorrow!

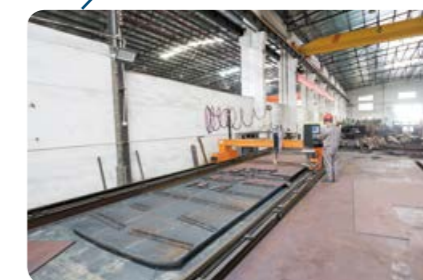

## 开卷 Uncoiler



▶ 悬臂式无支撑 Cantilever only (no OBBS) L  $\leq 10\text{T}$



▶ 高强度特殊设计 Ultra High Tensile steel special design H  $\leq 10\text{T}$



▶ 油磨线开卷 Uncoiler for No.4/HL line L  $\leq 25\text{T}$

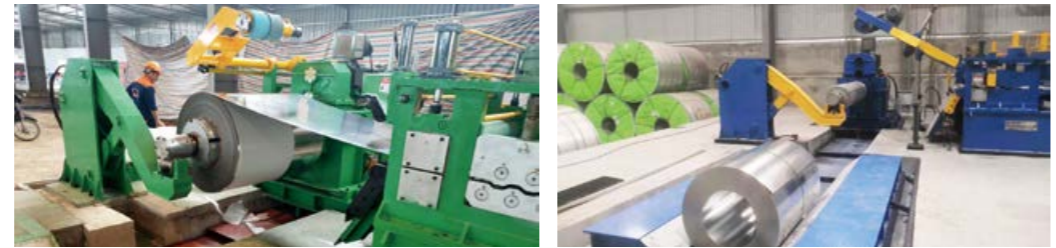

▶ 悬臂式有支撑 Cantilever with support (with OBBS) L M  $\leq 30\text{T}$



▶ 双头式非龙门压料 Double head type non-gantry hold down arm M  $\leq 30\text{T}$



▶ 双头式龙门压料 Double head type gantry hold down arm H  $\leq 40\text{T}$

## 预校平 Pre-leveler



▶ 预校平 Pre-leveler L M H

## 废边卷取 Scrap winder



▶ 卧式废边卷取 Horizontal scrap winder L M H



▶ 立式废边卷取 Vertical scrap winder L M H



▶ 离线废边机 Offline scrap baller L

分条 Slitter



▶ 单刀座与双刀座 Single & double L M H



▶ 胶圈脱料 Rubber ring L M H



▶ 板式脱料 Bakelite bar L

张力部分 Tension Unit



▶ 平板张力 Plate tension L M



▶ 三辊 / 五辊张力 3-5-roller tension M H



▶ 皮带张力 Belt bridle L



收卷 Recoiler



▶ 单收卷无支撑 Single without OBBS L

收卷 Recoiler



▶ 单收卷有支撑 Single with OBBS L M H



▶ 双收卷无支撑 double without OBBS L M H



▶ 油磨线收卷 Recoiler for No.4/HL line

下料 Unloader



▶ 小车坑式 Pit type coil car L M H

下料 Unloader



▶ 平地式 C 行车 Flatland C-type car L



▶ 一字 / 十字打包架 Turnstile of 2-arm/4-arm



▶ 钢卷翻斗车 Coil turner



▶ 钢带打包机 Strip packing machine

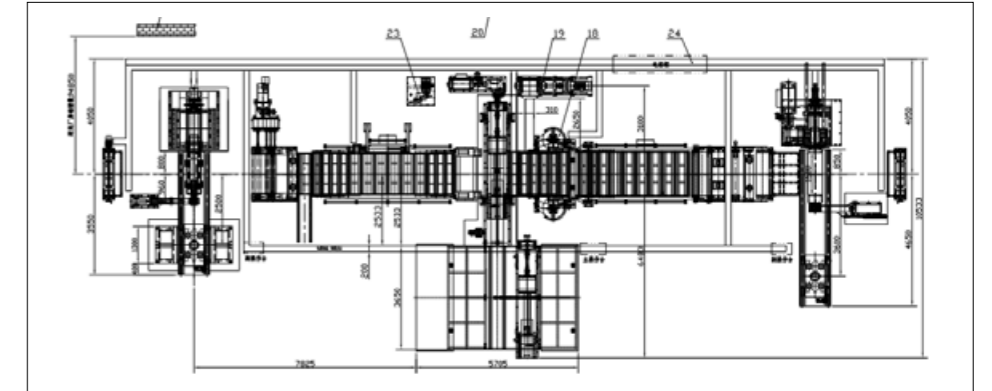

▶ SL,DH : 0.3 ~ 2.5mm × 1300mm L ≤ 25T

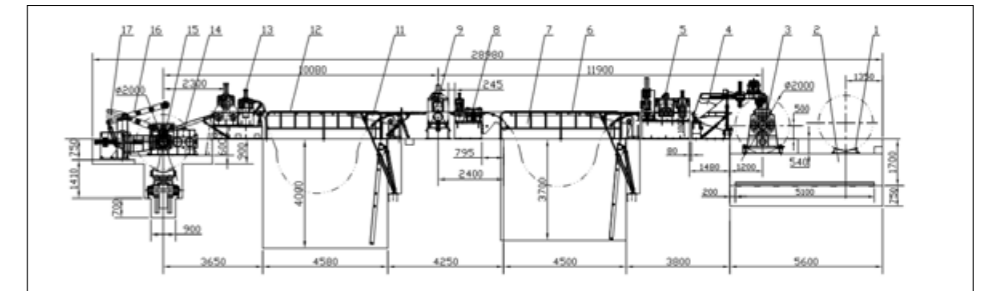

▶ SL : 2 ~ 7mm × 1700mm M ≤ 30T

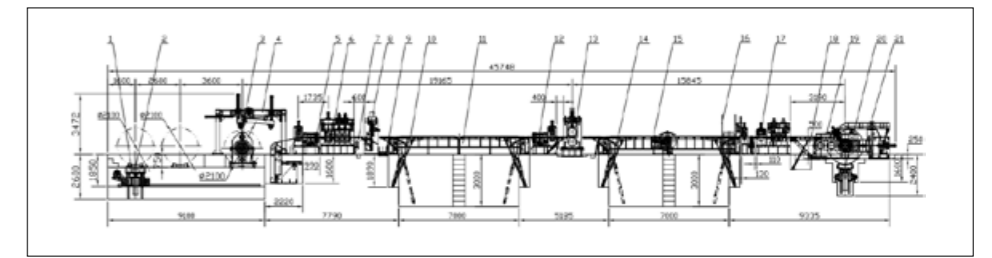

▶ SL : 3 ~ 12mm × 2200mm H ≤ 36T

整平横切机组 Cut to length Line  
停剪式 & 飞剪式 Stop type & Flying (rotary) type

L 轻型 Light gauge :  $\leq 3\text{mm}$   
M 中型 Medium gauge :  $\leq 8\text{mm}$   
H 重型 Heavy gauge :  $> 8\text{mm}$

YOUR BUSINESS NEEDS

A machine that consistently delivers,  
with outstanding durability

您需要一台经久耐用的机器

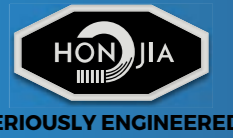

校平部分 Leveling unit



▶ 四重式 19 辊 4Hi-19 rolls L



▶ 四重式 15 辊 4Hi-15 rolls L M



▶ 四重式 13 辊 4Hi-13 rolls M H



▶ 四重式 11 辊 4Hi-11 rolls M H



▶ 二重式 9 辊 2Hi-9 rolls M H



▶ 六重式 19 辊 6Hi-19 rolls L



剪床 Shear



▶ 伺服停剪 Servo stop shear L



▶ 伺服追剪 Servo tracing shear L M H



▶ 气动离合剪 Pneumatic clutch shear M



▶ 液压闸剪 Hydraulic guillotine shear M

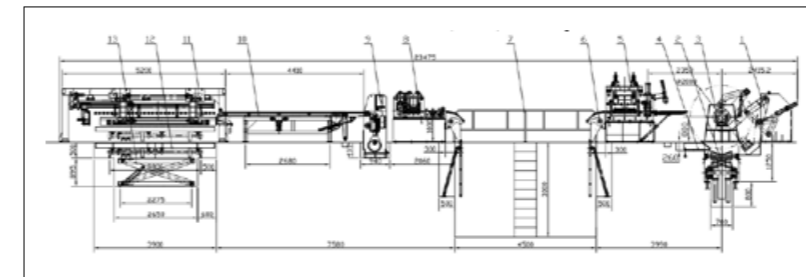

▶ CTL: 0.3~3mmx1600mm L  $\leq 25\text{T}$

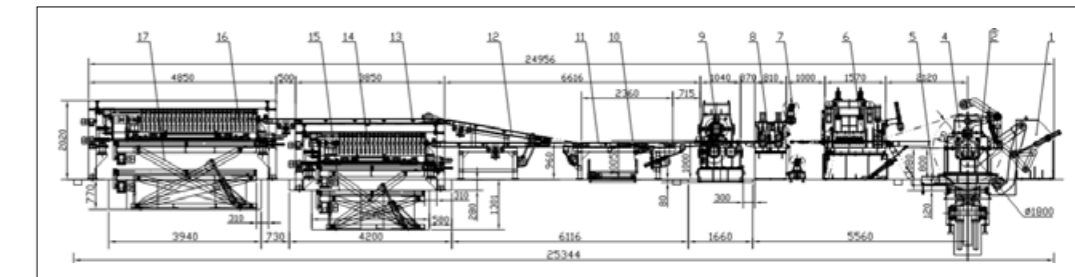

▶ FCTL: 0.5~3mmx1320mm L  $\leq 20\text{T}$

整平横切机组 Cut to length Line  
停剪式 & 飞剪式 Stop type & Flying (rotary) type

L 轻型 Light gauge :  $\leq 3\text{mm}$   
M 中型 Medium gauge :  $\leq 8\text{mm}$   
H 重型 Heavy gauge :  $> 8\text{mm}$

YOUR BUSINESS NEEDS

A machine that consistently delivers,  
with outstanding durability

您需要一台经久耐用的机器



剪床 Shear



▶ 飞剪 Flying shear (rotary shear)

自动叠料及出料 Auto-stacking & Unloader



▶ 停剪式出料平台 Exit platform for CTL



▶ 飞剪式出料平台 Exit platform for FCTL



▶ 飞剪式出料辊道 Exit roller for FCTL



# 纵横剪联合机组 Slitting & Cut to length combined line

- L** 轻型 Light gauge :  $\leq 3\text{mm}$
- M** 中型 Medium gauge :  $\leq 8\text{mm}$
- H** 重型 Heavy gauge :  $> 8\text{mm}$

Creating Value For Customers

IS THE ETERNAL PURSUIT OF THE COMPANY

为客户创造价值，是我们不懈的追求

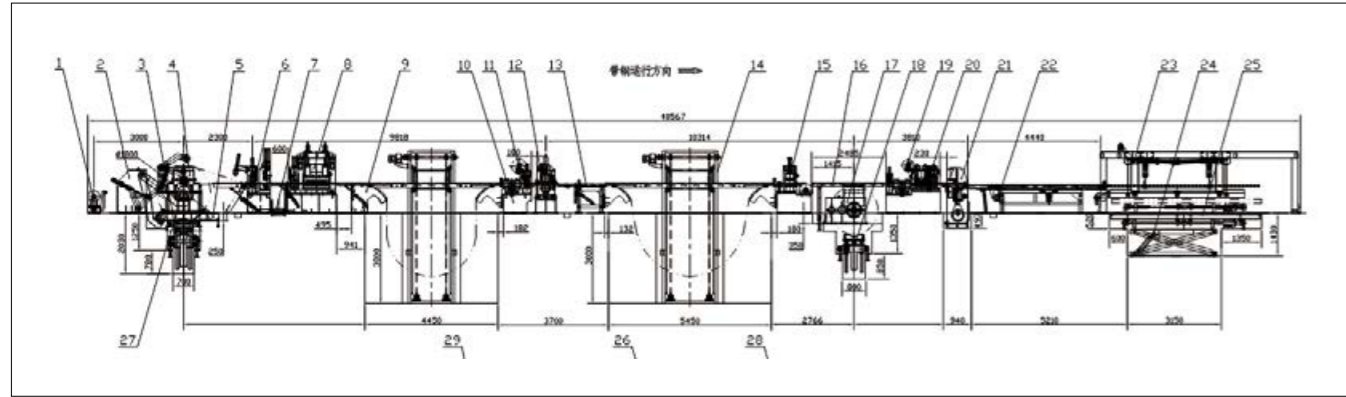

▶ SL.CTL : 0.5 ~ 3mm x 1600mm **L**  $\leq 25\text{T}$

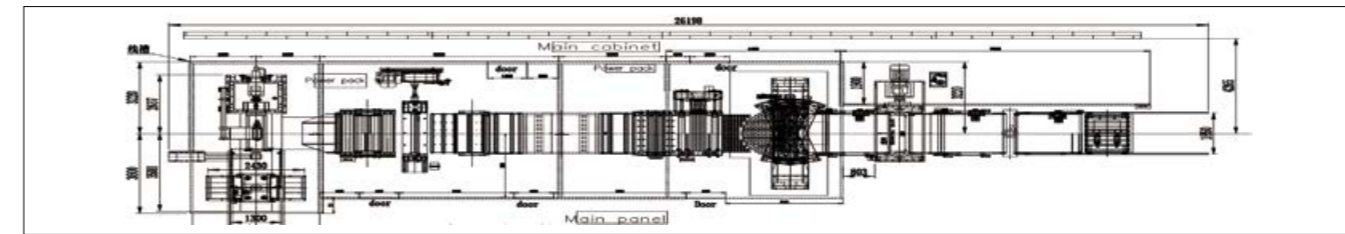

▶ SL.CTL : 0.2~1.5mm x 1600mm **L**  $\leq 10\text{T}$



# 纵横剪联合机组 Slitting & Cut to length combined line

- L 轻型 Light gauge :  $\leq 3\text{mm}$
- M 中型 Medium gauge :  $\leq 8\text{mm}$
- H 重型 Heavy gauge :  $> 8\text{mm}$

Creating Value For Customers

IS THE ETERNAL PURSUIT OF THE COMPANY

为客户创造价值，是我们不懈的追求

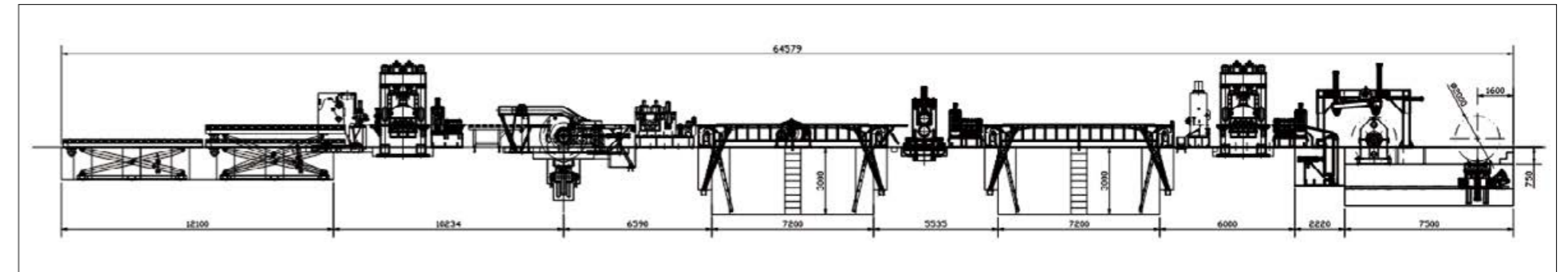

▶ SL.CTL : 5~16mm x 1800mm H  $\leq 35\text{T}$

SERIOUSLY ENGINEERED.

— for YOU !

为您研发智造，我们是认真的！

持续稳定 高效安全

我们只选用优良品质与品牌的零配件（以下列举品牌）

CONSISTENTLY SAFE HIGH-QUALITY

Our First- Class components with dramatic impact on your bottom line

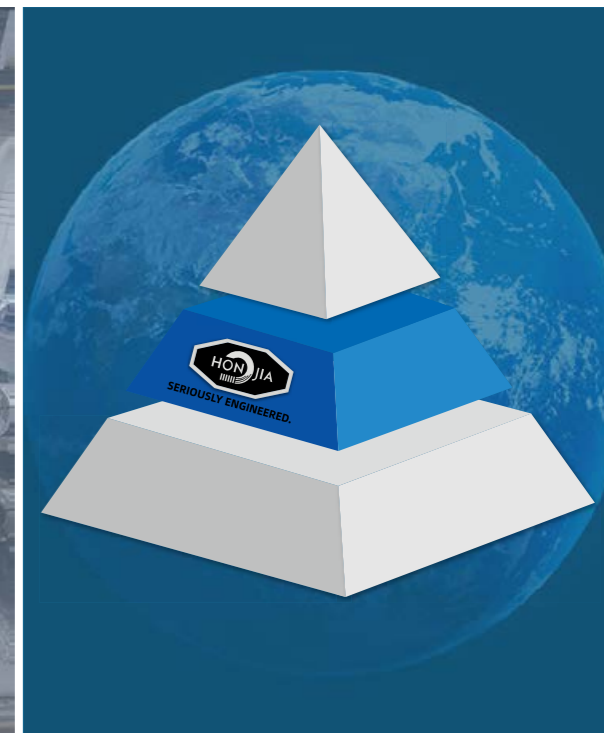

我们的服务

OUR SERVICE

- 售前技术支持 PRE-SALES TECHNICAL SUPPORT
- 设计，研发 R&D
- 空载试机 IDLE PRE-TEST
- 售后支持 AFTER SALES ASSISTANCE

买得起的好品质  
Affordable  
fine quality

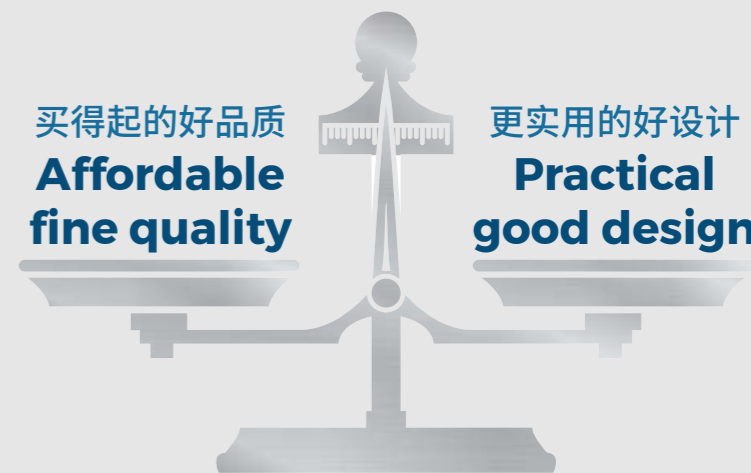

更实用的好设计  
Practical  
good design